

BENJAMIN[®]

EXPLODED VIEW & PARTSLIST

Marauder BP1763 (.177cal) & BP2263 (.22cal) PCP Rifles



Manufacture Start Date: 05/05/09

Updated 02/10/10

CROSMAN CORPORATION
RT 5 & 20
EAST BLOOMFIELD, NY 14443
Phone: 1-800-724-7486
Parts Order Fax: 585-657-5405
www.crosman.com

- This parts list is intended to be an informational guide in ordering parts. It is not instructional material and we therefore assume no responsibility for those who use the same without proper factory training.
- Please order by part number and description.
- Check or money order for the total price must accompany the order.
- For current prices contact Crosman Corporation at 1-800-724-7486 or visit our website www.crosman.com

PARTS LIST BP1763 BP2263
 Manufacture Start Date: 5/5/09
 PHASE 1

	PART NUMBER	DESCRIPTION
1	1763-001	Tube, Pressure
2	1763-100	Valve Asy. (pg.4)
3	1763-101	Fill Adaptor Asy. (pg.4)
4	1763-103	Stock Assembly
5	1763-104	Gauge Port Asy. (pg.4)
6	1763A105	Trigger Asy. (pg.5)
7	1763-106	Plunger Asy.
8	1763-004	Breech .177cal. (1763)
1	2263-004	Breech .22cal. (2263)
9	1763A102	Bolt Asy. .177cal (1763)
1	2263A102	Bolt Asy. .22cal (2263)
10	1763-058	O-Ring 1.5mm x 4mm (1763)
1	1761A023	O-Ring #2-009 (2263)
11	1761A023	O-Ring #2-009
12	1763-017	Barrel .177cal. 20" (1763)
1	2263-001	Barrel .22cal. 20" (2263)
13	1763-012	Cap, Pressure Tube
14	1763-005	Shroud, Barrel
15	2563-008	Barrel Band
16	2563-061	O-Ring, #2-022
17	1763-011	Cap, Fill Nipple
18	1763A010	Cap, Shroud
19	1763-014	Sleeve, Transfer Cart
20	1763-013	Mount, Shroud
21	1763-023	Set Screw, 8-32 x .25 FLTPT(2)
22	1763-033	Gauge, 3000 PSI
23	1761-017	Adapter, Gauge
24	1763-025	Bushing, Bolt Latch
25	1763-022	Screw, 8-32 x .188, SHCS
26	1763-024	Screw, 8-32 x .500, SHCS
27	1763-020	Spacer, Barrel Shroud
28	1763-009	Spring, Hammer
29	130-036	Breech Gasket (2)
30	1763A060	Baffle (4)
31	1763-035	Screw, 8-32 x .437, BHCS (4)
32	1763-029	Screw, 1/4-20 x 1.0 SHCS
33	1763-038	Guide, Hammer Spring
34	JTX-080	O-Ring, 2-113
35	JTX-080	O-Ring, 2-113

	PART NUMBER	DESCRIPTION
36	1763-027	Screw, 4-40 x 1.25 SCHS (2)
37	1763-021	Set Screw, 8-32 x .375 FLTPT (2)
38	397-036	O-Ring, #2-016, BUNA N
39	190B-008	O-Ring
40	1763-015	Hammer
41	1763A036	Striker
42	1763-066	Set Screw, 6-32 x .188 CUP PT.
43	1763-062	Plug, Binding
44	88-089	Set Screw, 6-32x.125 CUP HEX HD
45	1763-019	Screw, 10-32 x .25, SHCS

1 MAURADER .22cal (BP2263) Unique Parts

8	2263-004	Breech, .22cal.
9	2263A102	Bolt Assembly, .22cal.
10	1763A023	O-Ring, #2-009
12	2263-001	Barrel, .22cal, 20"

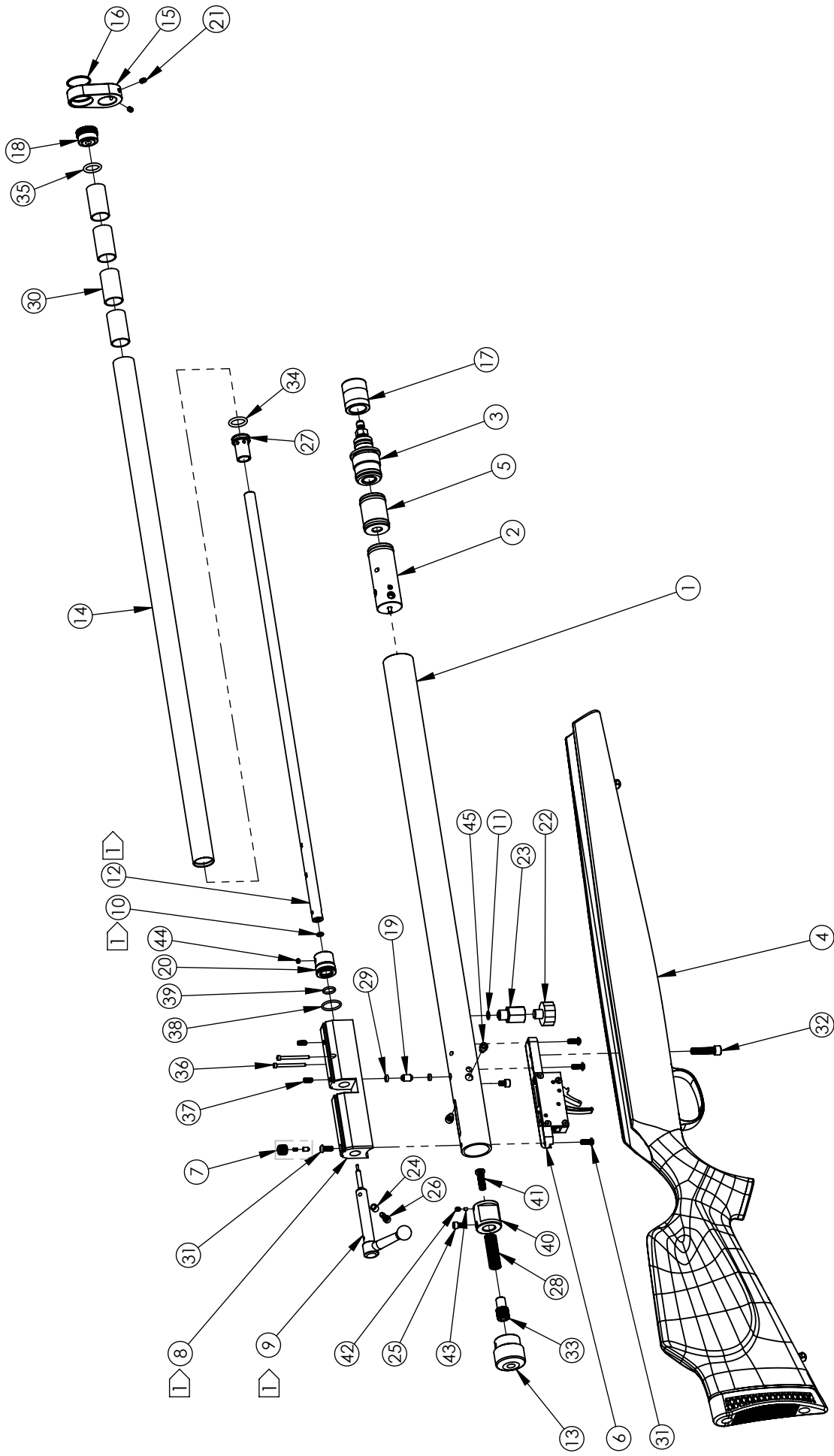

⌈ SEE UNIQUE PARTS LIST FOR UNIQUE .22 CALIBER MODEL COMPONENT

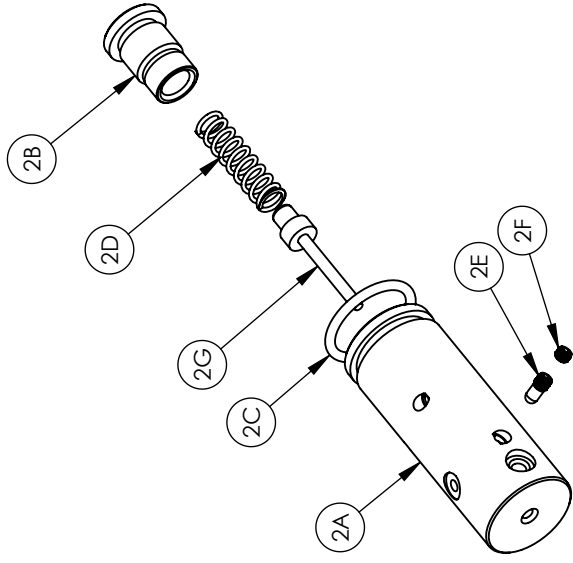

ITEM 2, VALVE ASSEMBLY

ITEM NO.	PART NUMBER	DESCRIPTION	QTY.
2A	1763-107	VALVE BODY	1
2B	1763A003	VALVE CAP	1
2C	1763-026	O-RING, AS568B-118	1
2D	1763-034	SPRING, VALVE	1
2E	1763-028	SCREW, VELOCITY ADJUSTMENT	1
2F	1763-059	SET SCREW, 8-32 x 125, BRASS	1
2G	1700-140	VALVE STEM, OVERMOLDED	1

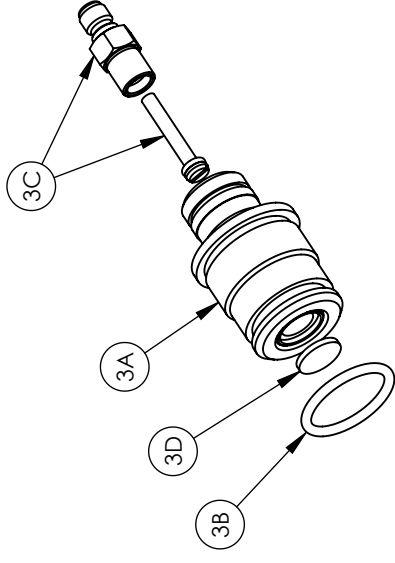

ITEM 3, FILL ADAPTER

ITEM NO.	PART NUMBER	DESCRIPTION	QTY.
3A	1763-018	HOUSING, FILL ADAPTER	1
3B	1763-026	O-RING, AS568B-118	1
3C	1761-106	NIPPLE, ADAPTER	1
3D	NS1200-047	SINTERED FILTER	1

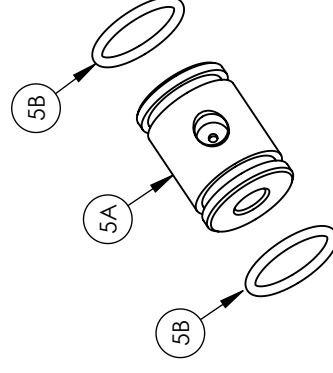

ITEM 5, GAUGE PORT

ITEM NO.	PART NUMBER	DESCRIPTION	QTY.
5A	1763-016	PORT, GAUGE	1
5B	1763-026	O-RING, AS568B-118	2

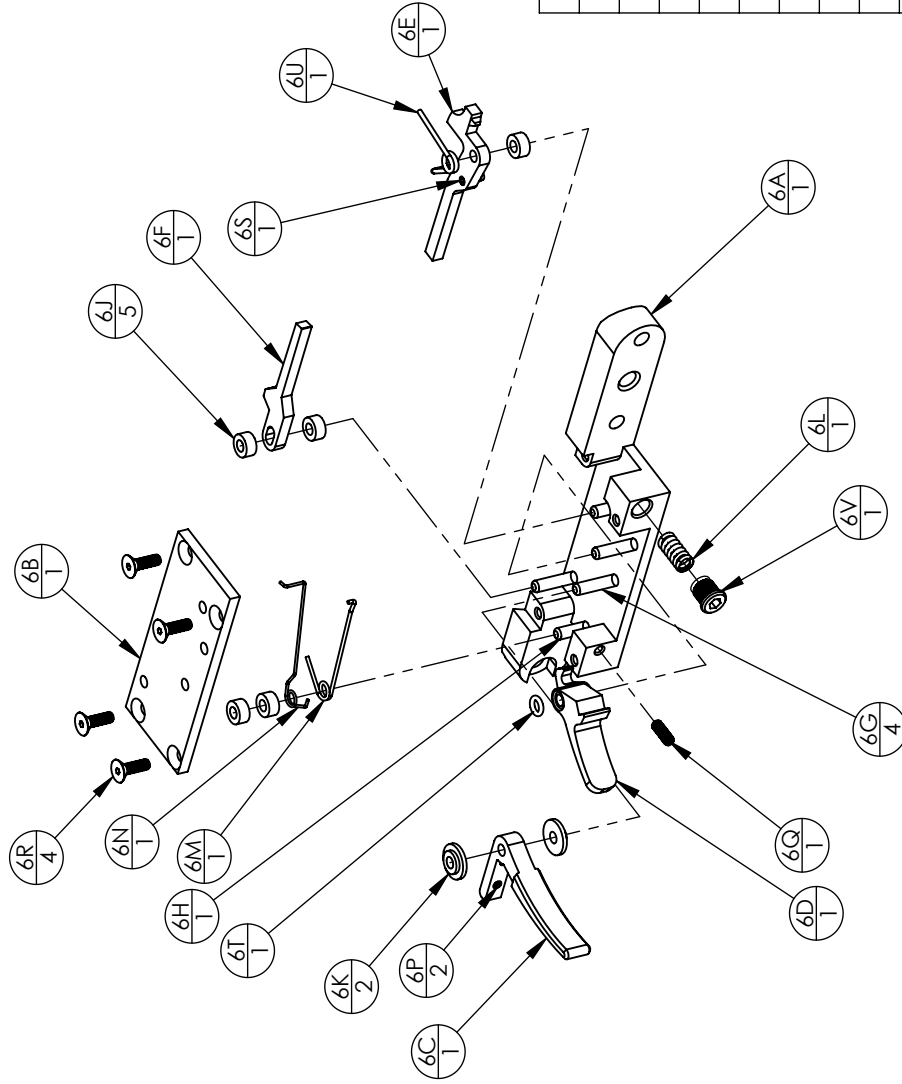

ITEM 6, TRIGGER ASSEMBLY

ITEM NO.	PART NUMBER	DESCRIPTION	QTY.
6A	1763-040	CASING, TRIGGER	1
6B	1763-041	COVER, TRIGGER CASING	1
6C	1763-042	TRIGGER	1
6D	1763-043	LEVER, SAFETY	1
6E	1763B044	LINK, TRIGGER	1
6F	1763-045	SEAR	1
6G	10804	PIN, DOWEL, .125 x .625	4
6H	1763-047	PIN, DOWEL, .125 x .500	1
6J	1763-048	SPACER, DELRIN, .25x.126x.123	5
6K	1763-049	SPACER, DELRIN, .375x.126x.086	2
6L	1763-050	SPRING, TRIGGER LINK	1
6M	1763-051	SPRING, SAFETY	1
6N	1763-052	SPRING, SEAR	1
6P	1763-054	SET SCREW, 4-40 x .188, OV PT	2
6Q	1763-055	SET SCREW, 4-40 x .312, OV PT	1
6R	1763-056	SCREW, 4-40 x .375, FHCS	4
6S	1763-057	ROLL PIN, .094 x .250	1
6T	397-062	SEAL, .177 BREECH O-RING	1
6U	1763-065	SPRING, TORSION, LINK	1
6V	1763A053	SCREW, 1/4-28 x .215, SOCKET HEAD	1